

Electrostatic Induction Spray-charging System (Embedded Electrode) for Knapsack Mist-blower

Dipak S. Khatawkar¹, D. Dhalin^{2*}, P. Shaji James³ and Seena R. Subhagan⁴

¹Department of FPME, KCAET, Kerala Agricultural University, India.

²Department of Agriculture Engineering, College of Agriculture, Vellayani, Kerala Agricultural University, India.

³ARS Mannuthy, Kerala Agricultural University, India.

⁴Department of Agriculture Entomology, RARS Ambalavayal, Kerala Agricultural University, India.

Authors' contributions

This work was carried out in collaboration among all authors. Authors DSK and DD designed the study, performed the statistical analysis, wrote the protocol and wrote the first draft of the manuscript. Author PSJ managed the analyses of the study. Author SRS managed the literature searches. All authors read and approved the final manuscript.

Article Information

DOI: 10.9734/CJAST/2020/v39i530549

Editor(s):

(1) Dr. Jerzy Nowacki, West Pomeranian University of Technology, Poland.

Reviewers:

(1) Şükrü Kitiş, Kütahya Dumlupınar University, Turkey.

(2) Marco Antonio Gandolfo, State University of Northern Parana, Brazil.

(3) Firas salim Al-Aani, Iowa State University, USA.

Complete Peer review History: <http://www.sdiarticle4.com/review-history/55756>

Original Research Article

Received 28 January 2020

Accepted 03 April 2020

Published 08 April 2020

ABSTRACT

The introduction of electrically charged sprays in agricultural application has become inevitable for better control on droplet transference with reduced drift with less spray chemical requirements. The study was under taken to develop an electrostatic induction spray charging system as attachment to knapsack mist-blower. A high voltage generator was fabricated on the basis of Cockcroft-Walton voltage multiplier principle with input of 6 V DC battery. A self-atomizing hydraulic nozzle was developed to deliver the droplet spectrum required for effective electrostatic charge induction. The prototype was evaluated for charge to mass ratio (mC. kg-1) at five electrode potentials (1 kV, 2 kV, 3 kV, 4 kV and 5 kV) at four electrode placement positions from atomization zone (0, 5, 10 and 15 mm). The charge mass ratio (CMR) value of spray cloud was measured using Faradays Cage at five positions from nozzle tip (50, 100, 150, 200 and 250 cm). The electrode voltage potential at 5 kV at its position 5 mm from the atomization zone shown the maximum CMR value of 1.088 mC.kg-1.

*Corresponding author: E-mail: dhalin.d@kau.in, dhalindharan@gmail.com;

In contrast with commercial system (ESS-MBP90) it was observed that except at 50 cm distance, the developed charging system, at 4 kV and 5 kV, surpassed commercial system in CMR from 100 cm to 250 cm distances. The droplet spectrum of the developed system was analysed and observed that the size of droplets were 100 to 200 μm . The developed system found to be cost effective and significantly consistent over the commercial one.

Keywords: Electrostatics; voltage-multiplier; charge to mass ratio; electrode placement position.

1. INTRODUCTION

In commercial agriculture, plant protection chemicals are vital for profitability, low food prices and for maintaining adequate food supply. Without them, crop losses could be as high as 50 per cent for field crops and up to 100 per cent for fruit crops and greenhouse ornamentals [1]. In agriculture, powered knapsack mist blower is one of the most popular and versatile pesticide application equipment due to its simplicity, ease of operation and inexpensiveness [2,3] though, these sprayers need to overcome the problems of low target deposition, distribution and penetration into the plant canopies [4,5]. The introduction of electrostatic spray technology for agricultural application especially in plant protection and epidemic prevention can provide superior performance in improving droplet size, size distribution and deposit rate on targets, adsorption, reduced wastage and uniformity [6,7,8,9]. The use of electrostatic spraying can increase the application efficiency by about 80 per cent with 60 per cent less spray chemical ingredients [10,8,11,12]. Electrostatics has significant potential on application of agricultural liquid formulations since charged particles can perform uniform spray coverage with considerably less quantity [13,14].

The three well known methods which can be adopted to charge the fluid spray are conduction charging, corona charging and induction charging. The method of 'Electrostatic Induction Charging' (EIC) works on the non-contact charge induction on the subjected spray fluid passing through the high voltage electrical field. As the method has no direct contact with the working fluid, the chances of getting high voltage shock to the operator are negligible and the power consumption is also considerably lower than the other methods [15,16]. This made the electrostatic induction charging as the most suitable method for charging agricultural spray liquids [17,18]. Majority of agricultural chemicals are applied as water based formulations, which has a polar molecular structure and a large value of electric dipole moment due to hydrogen

covalent bonds. On the basis of electro-chemistry of polar molecules, fine water droplets can be charged electrostatically [19,20,21]. The plants grounded to the earth shall be at zero potential; even though the metabolic processes of living plant body induces slight positive charge on the plant [22]. But this charge has been found to be distributed asymmetrically on plant surface, concentrated near the sharp protruding body parts such as leaf tips, spikes and especially floral parts.

In India, only a few attempts have been made so far in developing and testing indigenous electrostatic spray charging systems. Moreover, the development of an economical electrostatic spray charging system for an existing sprayer will be a boon to the Indian farmer. Hence, the development of an electrostatic induction charging attachment to a conventional "dormant" nozzle was contemplated with the following specific objectives:

- To develop a low cost electrostatic nozzle and charging system compatible to a DC power source.
- To study the dynamic charge acquisition and spray chargeability of the developed system.
- To evaluate the depositional characteristics of the charged spray on plant targets.

2. MATERIALS AND METHODS

2.1 Principles of Electrostatic Induction Spray Charging System

The method of electrostatic induction spray charging was adopted for this study by considering its known advantages over other charging methods such as high charge transferability, less hazardous to life and simplicity in construction. The system consists of a spray nozzle and electrode placed in the vicinity of spray atomization zone concentrically with the spray nozzle. When sufficiently high

voltage Direct Current (DC) is applied to the charging electrode and the spray liquid is grounded, an electrostatic field will be created around the electrode. The position of the electrode is fixed in such a way that it will be exposed to the maximum spray atomization area (Fig. 1). According to Gauss's Law, the maximum droplet charging occurs when the droplet formation zone is exposed to the maximum field strength. Therefore, for any liquid having non-zero electrical conductivity, an excess image charge will be accumulated on the grounded spray liquid with opposite polarity.

2.2 Development of Electrostatic Induction Spray Charging System

The design for an electrostatic induction charging arrangement for a conventional "duro mist" nozzle was conceptualized based on the available theoretical background of liquid particulate charging. Experimental prototypes of induction charging nozzle attachment was developed to suit a knapsack mist blower. The powered knapsack mist blower selected for the study was OLEOMAC-AM 162 with 4.5 HP, 2-stroke gasoline engine prime mover.

2.3 Development of Voltage Amplification Unit for HVDC Supply

For charging an aqueous spray electrostatically, a high voltage DC power supply is essential. The basic voltage amplification unit mainly consists of a diode pump voltage multiplier. It has a special arrangement of P-N junction diodes and capacitors with an alternating current input. The voltage amplification depends upon the number of stages of diode and capacitor ladder and the capacitance value.

2.4 Voltage Inverter Circuit

In order to convert input DC voltage from battery into an amplified Alternating Current (AC), an inverter circuit is necessary. It consists of a pulse generator and a high voltage transformer, in which the input DC voltage is converted into a pulsating square wave signal through the pulse generator circuit. This pulsating voltage is applied across the primary winding of the high voltage transformer, which then generates a sinusoidal alternating wave in the secondary winding due to mutual induction. This AC voltage can be used as an input source for the voltage amplification circuit.

2.5 Diode-Pump Rectification

A Cockcroft-Walton (C-W) voltage multiplier (Fig. 3) was developed based on the diode-pump rectifier circuit as shown in Fig. 2.

The figure illustrates the arrangement of diodes and capacitors with an AC voltage input (V). The circuit doubles the voltage output with a cascade arrangement of two diodes and two capacitors. However, the practical output voltage shows slight reduction due to ripple in the voltage amplification. The theoretical output voltage could be calculated by the formula as,

$$V_{output} = 2 \times N \times V_p$$

Where,

$$V_p = \text{Peak value of voltage supply}$$

$$N = \text{Number of capacitors in the circuit}$$

The practical voltage output differed slightly from the output voltage calculated theoretically due to the ripple effect in voltage amplification. Then it could be expressed in terms of Ripple voltage (V_R),

$$V_R = \frac{I \times N(N + 1)}{2 \times C \times F}$$

Where,

$$I = \text{Load current, A}$$

$$N = \text{No. of capacitors}$$

$$F = \text{Driving frequency, Hz}$$

$$C = \text{Capacitance, farads}$$

Considering the alternating sine wave input, the lower rectifier causes the series capacitor to charge to the peak voltage of the input wave form. This occurs during the negative going excursions of the wave form and during positive going half-cycle, the charged capacitor and the transformer become effective in the series. This series arrangement charges the output capacitor to the sum of these two voltages and in turn, become equal to the twice of the peak value of the transformer voltage.

2.6 High Voltage Generator (Voltage Amplifier)

A high voltage generator was fabricated on the basis of Cockcroft-Walton voltage multiplier principle, using 6 V DC battery with 2500 mA current as an input source. It consisted of a high

voltage transformer with different stages of cascade multiplier having IN4007 diodes and 3 kV ceramic capacitors (1.8 μ F). As the voltage-multiplier circuit requires an AC input, an inverter circuit was introduced in between the DC input battery and the high voltage transformer. The pulse generator in the inverter circuit was fabricated with NE555 standard timer Integrated Circuit and two 3296-Electronic Potentiometers

to adjust the duty cycle and frequency. The different stages of HVDC generator were designed to give output voltage of 1000 V, 2000 V, 3000 V, 4000 V and 5000 V by using rheostat [23,24]. The whole HVDC generator unit was accommodated in an insulated box to avoid arcing, direct contact with the operator or with any other conducting materials to avoid any sort of casualty.

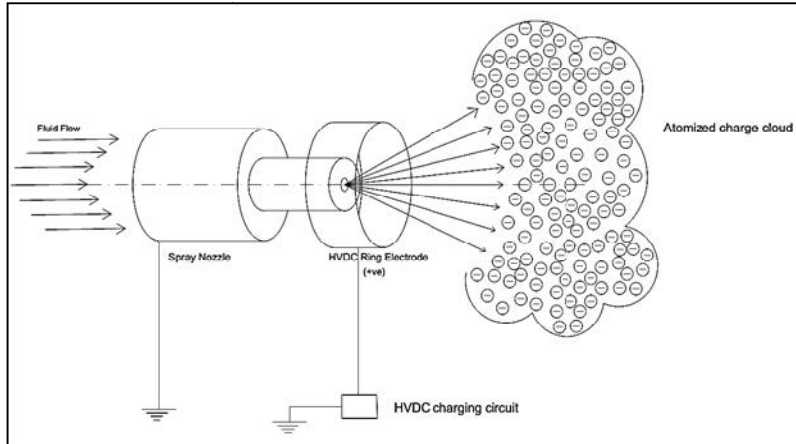

Fig. 1. Electrostatic induction spray charging system

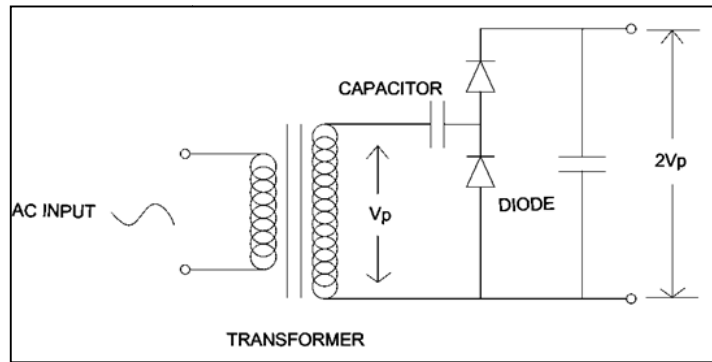

Fig. 2. Diode-Pump Rectifier

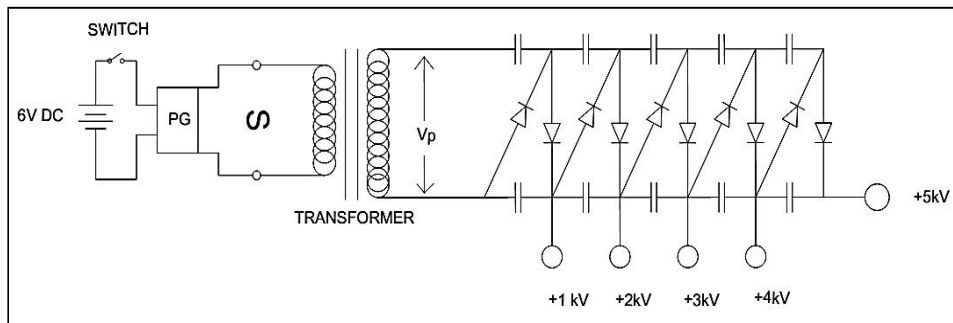

Fig. 3. High Voltage generator circuit

2.7 Development of Embedded High Voltage Electrode Assembly

For inducing the high voltage onto the spray droplets, a suitable electrode carrier assembly (Fig. 4) with embedded electrode position was developed.

The electrode carrier was designed in such a way that, introduction of the electrode assembly to an existing system must not produce any type of hindrance in the air-flow generated by blower. A slope of 40 per cent was provided to the inner edge of the carrier to minimize the air-flow turbulence. A slot of 5 mm × 10 mm (width × depth) was provided externally from the outer surface of the carrier, for placing the HV ring electrode. On the basis of proper insulation as well as machinability, a Cast Nylon-6 circular section rod of 75 mm diameter was used as fabricating material for the assembly. The copper wire ring electrode was then embedded in the slot provided on the carrier sleeve. The embedded design facilitated proper insulation of the charging electrode against wetting by tiny

spray droplets which may reduce the spray chargeability.

2.8 Development of Self-Atomizing Hydraulic Nozzle

For producing required range of fine droplet size, an entirely different type of spray nozzle was designed and fabricated (Fig. 5), consisting a single orifice fluid discharge point with 0.10 mm opening diameter, working under hydraulic pressure ranging between 250 to 300 kPa.

The 12-24V DC operated low discharge high pressure diaphragm pump was selected to operate the nozzle, as it suited best for restricted space and corresponding addition in the gross weight of the whole equipment. The diaphragm pump model LD-HP SF25, make Sea-Flo Pumps Ltd. (12-24V DC, 250 kPa output pressure) was used to pressurize the spray liquid. Nozzle was fabricated with Polypropylene material, provided with internal lateral entry of spray fluid towards the discharge point (Fig. 6).

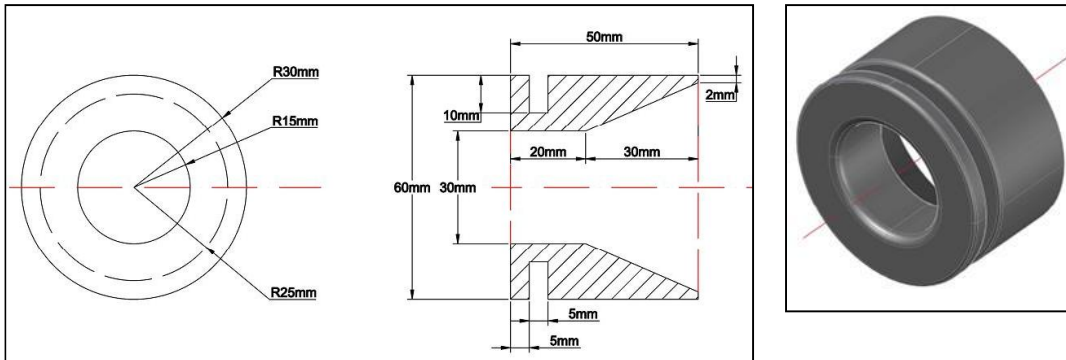

Fig. 4. Embedded electrode assembly

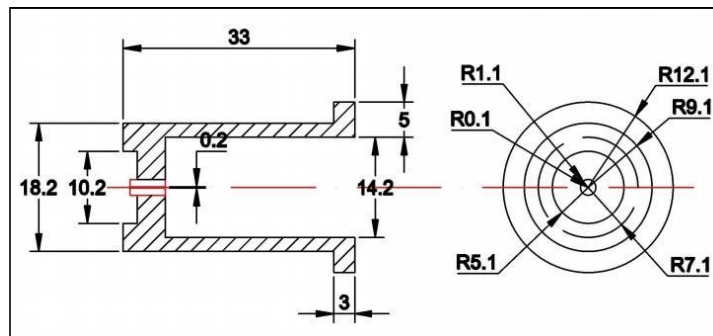

Fig. 5. Self-Atomizing hydraulic nozzle

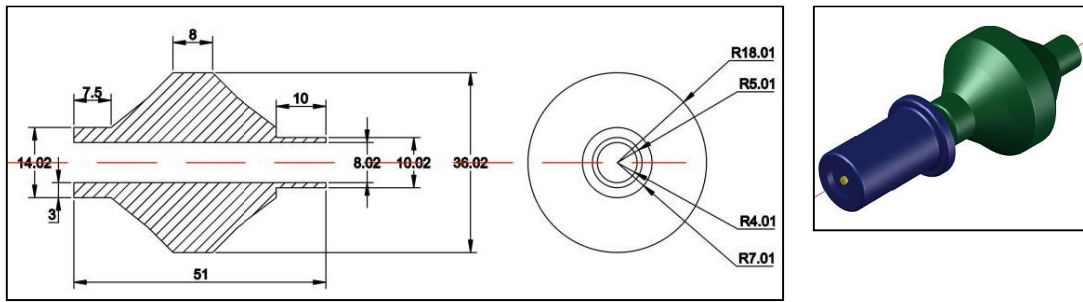

Fig. 6. Adapter for nozzle fitment

The new design helped to get hollow-cone spray pattern with fine spray. The nozzle was operated separately with diaphragm pump and all the components were assembled together to form a single unit as Self-Atomizing Pressure operated nozzle type Electrostatic Induction Charging Knapsack Mist-Blower.

The final prototype of electrostatic induction spray charging unit attached to the powered knapsack mist blower was then evaluated under laboratory as per the specific experimental procedure (Fig. 7).

2.9 Laboratory Experimental Setup

Measurement of high voltage, generated by the fabricated HVDC generator unit was one of the critical factors, since this high voltage was the basic parameter influencing the induction charging of spray.

Similarly, the current induced in the spray was also an important factor in the induction charging; hence it was crucial to measure accurately (Fig. 8). The digital multimeter Model KM-5040T/BM-812a and a high voltage probe Model PD-28 of make KUSAM-MECO Brymen, Ind. Ltd. was used for the measurement of voltage and current generated by the HVDC generator unit. The Digital Multimeter (DMM) was equipped with RS-232 Computer Interface-Data Logging Software through which data was collected in computer via infrared serial bus cable at the data collection speed of one reading per second.

2.9.1 Faraday's cage

The induction spray chargeability of the developed electrostatic induction spray charging system could be measured only by measuring the charge acquisition by the spray cloud. The charge acquired by the spray cloud is directly proportional to the charge induction capacity of the HV electric field produced around the electrode by the developed system. Faraday's

Cage is one of the simple and accurate methods of measuring the spray cloud charge, in the laboratory [25,26]. The tap water was used as the spray fluid and it was required to measure the induced spray cloud voltage instantaneously. The Faraday's cage was fabricated with general thumb rules and fabricated accordingly with a Polypropylene vessel and Aluminium mesh (Fig. 9).

The shielding Aluminium mesh was wrapped around the insulating vessel of cylindrical shape, keeping it in a horizontal position, to avoid atmospheric electric field interference to the charge collector mesh. The charge collector Aluminium mesh was placed inside the vessel, vertically at marked intervals measured from the spray intake end of vessel. The connections were made between the Faraday's cage and Digital Multimeter enabled with Computer Interface Data Logging Software, as ground wire to the grounded shielding mesh and positive terminal to the charge collector mesh. The charge to mass ratio (CMR) was calculated from the charge collected from the spray cloud and mass flow rate of the spray liquid.

2.10 Experimental Procedures

The laboratory experimental procedures were followed with corresponding setups for measurement of charge induction over the spray cloud by developed HVDC induction spray charging system and for measurement of spray droplet size [27,28,29]. The laboratory experimental setup (Plate. 2) for spray charge acquisition was,

- Voltage Potential: 1 kV, 2 kV, 3 kV, 4 kV and 5 kV
- Electrode Position: 0 mm, 5 mm, 10 mm and 15 mm ahead of atomization zone
- Charge carrying capacity: CMR was measured at 50 cm, 100 cm, 150 cm, 200 cm and 250 cm from the nozzle.



Fig. 7. Electrostatic charging unit with mist blower



Fig. 8. Experimental set up for cloud charge measurement

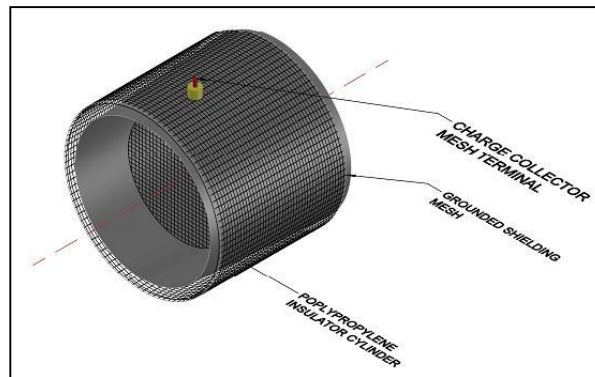

Fig. 9. Faraday' Cage

The performance of the developed spray charging system was compared with the commercial electrostatic sprayer model ESS-MBP90 make Electrostatic Spraying Systems Inc., Watkinsville as shown in Fig. 10 and specifications of which are given below:

- No. of nozzles: 01 (one)
- Flow rate: 9.5 L hr^{-1}
- Droplet size: 40 microns
- Spray range: 6 m

2.11 Measurement of Spray Droplet Size

- Overall dimensions (H×W×L): 1.1 m × 0.6 m × 1.8 m
- Air-compressor prime mover: 5 kW Briggs & Stratton gasoline engine

The spray droplet size was measured at identical operating conditions since the spray chargeability was inversely proportional to the droplet size. Bromide Photo paper of size 5 cm × 5 cm was

used for capturing the droplet spectrum, by passing it through the continuous spray swathe. Methylene Blue dye was used for pigmenting the spray fluid. Pigmented spray solution was prepared by dissolving 20 g of dry Methylene Blue dye in 1 litre of water. High resolution Scanner was used for scanning photo papers with 1200 dpi scan resolution. Computer based image analysis software Deposit Scan (Image-J-2016, Version 1.37.1 platform) was used to analyse the scanned images and spectrum. Deposit Scan is a portable scanning system for spray deposit qualification developed by USDA-ARS Application Technology Research unit, Wooster (USA). The image processing software readily analyzed the scanned image and displayed the results in terms of droplet size distribution (DV_{10} , DV_{50} and DV_{90}), droplets per unit area, and per cent coverage of deposits within the selected image area, total number of droplets count, individual spot area and actual droplet diameter. The software converted the individual spot (A_s) area into actual droplet diameter (D_d) using following equation,

$$D_d = 1.06 A_s^{0.455}$$

2.12 Deposition Characteristics

The spray deposition was quantified in terms of deposition per unit leaf area sprayed, by Leaf-wash method [30,4]. In leaf wash method leaf samples from treated plant targets were collected randomly and different parts of the plant surface. Dye residues were washed from the top side and under sides of the leaves separately. Dye solutions thus collected were evaluated for transmittance with a Spectrophotometer and compared with the calibration from known washed deposits to determine dye deposition on

each samples. The 1.5 g of fluorescent tracer (DAY GLO type GT-15-N Fluorescent Blaze Orange dye) was dissolved in 1000 ml of water, making concentration of tracer liquid 1500 ppm. This concentration of tracer residue on the target was analogous to pesticide active ingredient of an actual spray solution. This facilitated a direct correlation of relative deposition efficiencies of the electrostatic versus conventional spraying techniques. After spray, the spray fluid deposited on water sensitive paper or leaf surface were retrieved and the dye was extracted by washing with known quantity of double distilled water.

The recovered tracer concentration was analysed for optical density (absorbance) with Spectrophotometer. Spectrophotometer was pre calibrated with double distilled water representing zero absorbance reading. Then further calibration was carried out in the visible region of the electromagnetic spectrum of wave length (λ) 555 nm, which is same as that of fluorescent tracer material and commercial agricultural chemicals. Solutions of known standard concentrations (ppm) of the tracer were prepared and measured for their optical density on the spectrophotometer. The concentration of the tracer of the sample was directly measured by the spectrophotometer in terms of ppm.

The percentage deposition or deposition efficiency was calculated based on the amount of active ingredient deposited on the target surface to the total amount of active ingredient applied while spraying.

$$\text{Deposition efficiency (\%)} = \frac{\text{Active ingredient deposited on target}}{\text{Total active ingredient applied}} \times 100$$



Fig. 10. ESS-MBP90 - Electrostatic Spraying Systems Inc., Watkinsville

2.13 Statistical Analysis

The Completely Randomized Design (CRD) with General Linear Model (GLM) multiple comparisons including Single Factor ANOVA were done to determine whether the difference between the performances of developed model and commercial one were significant. The five charging voltages (1kV, 2kV, 3kV, 4kV and 5kV), Electrode placements (0 mm, 5 mm, 10 mm and 15 mm ahead of the spray atomization zone) and Charge carrying distances (50 cm, 100 cm, 150 cm, 200 cm and 250 cm coaxially from the nozzle tip) were the independent variables, whereas the CMR (Charge to Mass Ratio) with three replications was taken as the dependent variable for the statistical analysis. All the statistical procedures were conducted using computer based data analysis software SPSS (Ver. 2016), IBM Inc.

3. RESULTS AND DISCUSSION

The embedded electrode electrostatic induction charging prototype has shown the highest CMR value (1.088 mC.kg^{-1}) at charging voltage potential of 5 kV for electrode placement-II (5 mm) at charge carrying distance of 50 cm. The CMR values were observed gradually increasing (from 0.422 to 1.088 mC.kg^{-1}) with increasing electrode potential (from 1 kV to 5 kV) and decreasing with increasing charge carrying distance (50 cm, 100 cm, 150 cm, 200 cm and 250 cm coaxially from the nozzle tip). There was a slight (5% to 10%) reduction observed in the overall charge induction with the electrode placements other than 5 mm ahead of spray atomization.

This result could be justified by the atomization lag of the nozzle i.e. just after the nozzle orifice, the water performed like a sheet immediately before the atomization. This lag restricted the formation of the droplet and hence the charge induction in case of EPP 0 mm. Whereas in case of EPP 10 mm and EPP 15 mm, the droplets formed at the atomization zone were rapidly carried away by the high velocity air stream, resulted reduction of exposure time of droplets towards electrostatic field, and caused a slight reduction in the charge induction on the droplets. The observed spray droplet size measured at constant nozzle operating pressure (250 kPa) and at 1.0 m, 1.5 m and 2.0 m horizontal distance was in the range of $80 \mu\text{m}$ to $250 \mu\text{m}$, which was found to be in the required spectrum of effective electrostatic induction chargeability of the spray. The electrostatically charged sprays achieved higher (1.5 to 2 folds) deposition efficiency (60 to 70%) than the uncharged spray (25 to 40%) on overall plant body i.e. Leaf top, under leaf and stem (Table 1).

3.1 Comparison with Commercial Electrostatic Sprayer

The developed electrostatic spray charging system was evaluated for CMR in comparison with existing commercial electrostatic sprayer of make Electrostatic Spraying Systems (ESS) Inc., Watkinsville (G.A.) Model-ESS-MBP90. The CMR values were measured for both developed and existing ESS sprayer at different distances (50 cm, 100 cm, 150 cm, 200 cm and 250 cm) coaxially from the spray nozzle tip (Table 2).

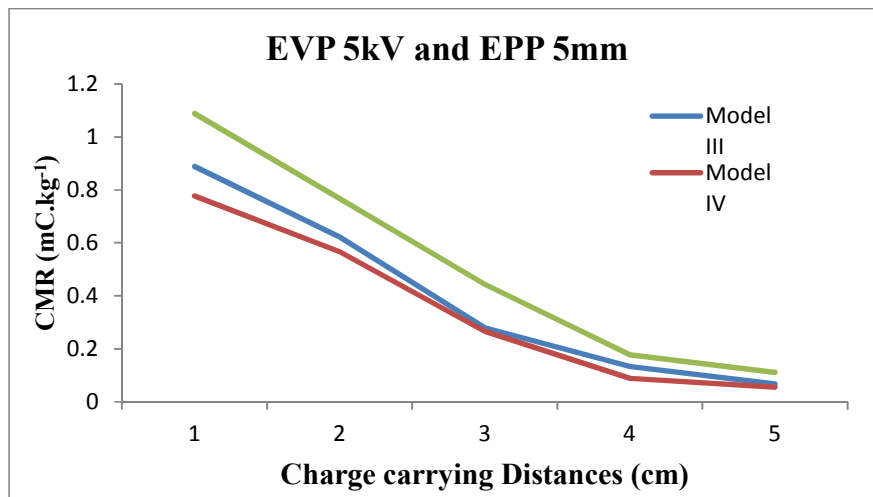

Fig. 11. Effect of Charge carrying distance on CMR

Table 1. Depositional characteristics

Plant Target	Deposition Efficiency, %		
	Electrostatic Spray (D_{v50} , μm)		Uncharged air-assisted spray (90 μm)
	Commercial ESS (40 μm)	Developed Prototype (90 μm)	
a. Leaf Top Surface	65 to 70	60 to 70	30 to 40
b. Leaf Bottom	55 to 65	50 to 60	25 to 30

Table 2. CMR comparison between commercial and developed system

Sprayer Model	CMR (mC.kg^{-1}) at distances from the nozzle				
	50 cm	100 cm	150 cm	200 cm	250 cm
Commercial ESS	2.121	0.561	0.221	0.044	0.022
Developed Prototype	1.088	0.677	0.444	0.177	0.111

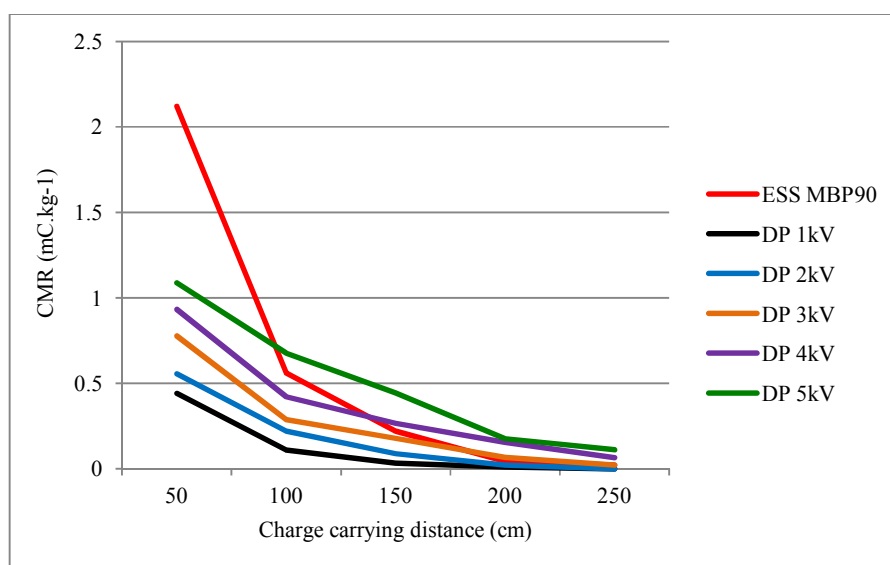

Fig. 12. Developed Prototype Vs. Commercial ESS-MBP90 sprayer

The maximum CMR (2.12 mC.kg^{-1}) was observed at 50 cm distance away from nozzle for commercial electrostatic sprayer (ESS-MBP90), followed by prototype (1.088 mC.kg^{-1}) at 5 kV electrode potential. The observed CMR values were ranged between 0.022 mC.kg^{-1} to 2.121 mC.kg^{-1} and 0.111 mC.kg^{-1} to 1.088 mC.kg^{-1} for commercial ESS sprayer and developed system respectively from 250 cm to 50 cm distance from the spray nozzle (Fig. 11).

The commercial electrostatic sprayer utilizes high pressure compressed air to atomize the spray liquid by air-blast at liquid delivery rate of 150 ml.min^{-1} . The developed self-atomizing nozzle atomizes the spray liquid at flow rate of 90 ml.min^{-1} by virtue of hydraulic pressure through portable 12V DC diaphragm pump and was independent of air velocity. Hence the air stream

from blower was utilized only for guiding the charged spray droplets towards the target.

4. CONCLUSIONS

An experimental prototype of induction charging nozzle attachment was developed to suit a knapsack mist blower (OleoMac-AM162). The high voltage generator was fabricated on the basis of Cockcroft-Walton voltage multiplier principle, using 6 V DC battery with 2500 mAh current capacity as an input source. The developed electrostatic spray charging system was evaluated for the spray chargeability in terms of Charge-to-Mass Ratio (CMR). The maximum CMR of 2.12 mC.kg^{-1} was observed at 50 cm distance away from nozzle with the charging electrode potential at 5 kV. The electrostatic charging of the spray effectively

enhanced the deposition efficiency by 40 – 70 per cent compared to the uncharged spray application.

ACKNOWLEDGEMENT

The research was funded by the Kerala Agricultural University, Kerala, India.

COMPETING INTERESTS

Authors have declared that no competing interests exist.

REFERENCES

- Oerke CN. Crop losses to pests. J. Agric. Sci. Cambridge University Press. 2006; 144(1):31-43.
- Abhilash PC, Singh N. Pesticide use and application: An Indian scenario. J. Hazard. Mater. 2009;165:1-12.
- Bindra OS, Singh H. Pesticide application equipment. Published by Mohan Pramlani, Oxford and IBH Publishing Co., Delhi. 1971;61-157.
- Patel MK, Sahoo HK, Nayak MK, Kumar A, Ghanashyam C, Amod K. Electrostatic Nozzle: New trends in agricultural pesticide spraying. Int. J. Electr. & Electronics Eng. 2015;6-11.
- Patel MK, Sahoo HK, Nayak MK, Kumar A, Ghanashyam C, Kumar A. Electrostatic nozzle: New trends in agricultural pesticides spraying. SSRG International Journal of Electrical and Electronics Engineering; 2016.
- Bowen HD, Splinter WE, Carleton WM. Theoretical implications of electrical fields on deposition of charged particles. Trans. ASAE. 1964;7(1):75–82.
- Law SE. Agricultural electrostatic spray application: a review of significant research and development during the 20th century. Journal of Electrostatics. 2001;51-52:25-42.
- Law SE, Lane MD. Electrostatic deposition of pesticide spray onto foliar targets of varying morphology. Trans. ASAE. 1981; 24(6):1441–1445.
- Wang ZT, Wen JL, Wang XY. High voltage electrostatic spray. High Volt. Eng. 2008; 34(5):1067-1072.
- Law SE, Cooper SC. Depositional characteristics of charged and uncharged droplets applied by an orchard air carrier sprayer. Transactions of the ASAE. 1988; 31(4):984-989.
- Mishra P, et al. Studies on effect of electrostatic spraying in orchards. Agric. Eng. Int., J. CIGR. 2014;16(3):60-69.
- Sumner HR, Herzog GA, Sumner PE, Bader M, Mullinix BG. Chemical application equipment for improved deposition on cotton. J. Cotton Sci. 2000; 4(1):19–27.
- Kirk IW, Hoffmann WC, Carlton JB. Aerial electrostatic spray system performance. American Society of Agricultural Engineers. 2001;44(5):1089–1092.
- Maski D, Durairaj D. Effects of electrode voltage, liquid flow rate, and liquid properties on spray chargeability of an air-assisted electrostatic-induction spray-charging system. J. Electrostat. 2010; 68(2):152–158.
- Maynagh BM, Ghobadian B, Jahannama MR, Hashjin TT. Effect of electrostatic induction parameters on droplets charging for Agricultural Application. J. Agric. Sci. Technol. 2009;11:249-257.
- Ru Y, Zheng JQ, Zhou HP. Electric field distribution produced by circular electrode of induce charging nozzle. Trans. Chin. Soc. Agric. Eng. 2008;24:119-122.
- Yamane S, Miyazaki S. Study on electrostatic pesticide spraying system for low-concentration, high-volume applications. JARQ. 2017;51(1):11–16.
- Yu D, Castle GSP, Adamiak K. Dynamic induction charging of particles with finite conductivity. IEEE Trans. Ind. Appl. 2010; 46(3):1159-1165.
- Kihm KD, Kim BH, McFarland AR. Atomization, charge and deposition characteristics of bipolarly charged aircraft sprays. Atomization and Sprays. 1992;2: 463-481.
- Law SE, Bowen HD. Charging liquid spray by electrostatic induction. Transactions of the American Society of Agricultural Engineers. 1966;9(4):501- 506.
- Lv TG. Study of electro-spray system characteristics. J. Agric. Mechanizat. Res. 2009;8:54-70.
- Oyarce P, Gurovich L. Electrical signals in avocado trees - Responses to light and water availability conditions. Plant Signaling & Behavior. 2010;5(1):34-41.
- Gupta CP, Singh G, Muhamein M, Dante ET. Field performance of a hand-held

- electrostatic spinning-disc sprayer. Trans. ASAE. 1992;35(6):1753-1758.
24. Gupta CP, Singh G, Parameshwar kumar, M, Ganapathy S. Farmer driven electrostatic low-volume sprayer. Innovative Scient. Res. U.S.-Israel CDR program, AIT, Bangkok. 1989;1-21.
25. Almekinders H, Ozkan HE, Reichard DL, Carpenter TG, Brazee RD. Spray deposition patterns of an electrostatic atomizer. Trans. ASAE. 1992;36(6):1361-1367.
26. Law SE. Electrostatic induction instrument for tracking and charge measurement of airborne agricultural particulates. Trans. ASAE. 1975;40-47.
27. Mamidi V, Ghanashyam C, Patel MK, Reddy V, Kapur P. Electrostatic hand pressure swirl nozzle for small crop growers. Int. J. Appl. Sci. & Tech., Res. Excellence. 2012;2(2):164-168.
28. Robson S, Mauri MT, Fernandes HC, Monteiro PM, Rodrigues, Cleyton BA. Parameters of electrostatic spraying and its influence on the application efficiency. Rev. Ceres, Vicosa-Brazil. 2013;60(4):474-479.
29. Shrimpton JS, Yule AJ. Eletro-hydro dynamics of charge injection atomization regimes and fundamental limits. At. Sprays. 2003;13:173-190.
30. Hoffmann WC, Hewitt AJ. Comparison of droplet imaging systems for water-sensitive cards. Proc. Asp. Appl. Biol. 2004;71:463-466.

© 2020 Khatawkar et al.; This is an Open Access article distributed under the terms of the Creative Commons Attribution License (<http://creativecommons.org/licenses/by/4.0>), which permits unrestricted use, distribution, and reproduction in any medium, provided the original work is properly cited.

Peer-review history:

The peer review history for this paper can be accessed here:
<http://www.sdiarticle4.com/review-history/55756>