



Portable Air Quality Detector Using DSM501A Dust Sensor and Arduino Uno

Iftekhar Uddin Mullick ^a, Khan Atik Faisal ^a,
Tarikul Islam Nishat ^a and Muhibul Haque Bhuyan ^{b*}

^a Department of Computer Science and Engineering, American International University-Bangladesh (AIUB), Dhaka 1229, Bangladesh.

^b Department of Electrical and Electronics Engineering, American International University-Bangladesh (AIUB), Dhaka 1229, Bangladesh.

Authors' contributions

This work was carried out in collaboration among all authors. Author IUM generated the concept, designed the study, simulated, and implemented the whole system. Author KAF wrote the codes, simulated, and implemented them, and wrote the draft manuscript. Author TIN generated the simulation and experimental results and performed the cost analysis and comparison. All authors read and approved the final manuscript. Author MHB executed the testing, and results analysis, steered the entire work, reviewed the papers, and finalized the manuscript in the current format.

Article Information

DOI: 10.9734/JERR/2024/v26i51143

Open Peer Review History:

This journal follows the Advanced Open Peer Review policy. Identity of the Reviewers, Editor(s) and additional Reviewers, peer review comments, different versions of the manuscript, comments of the editors, etc. are available here: <https://www.sdiarticle5.com/review-history/115862>

Original Research Article

Received: 02/03/2024

Accepted: 09/04/2024

Published: 12/04/2024

ABSTRACT

Aims: The primary feature of this research is to design a circuit that can analyze the air around the system and determine the quality of the air.

Study Design: This paper reports on the design and implementation of a portable air pollution analyzer using Arduino Uno, DSM501A dust sensor, LCD, switches, buzzer, and multiple LEDs. The air pollution analyzer system was designed using a combination of hardware and software techniques to measure air pollution properly.

*Corresponding author: Email: muhibulhb@aiub.edu;

Place and Period of Study: The research was accomplished by the authors in a group of two students under the grasp of a professor as a part of one of his course capstone projects for the Bachelor of Science in Electrical and Electronic Engineering degree at the American International University Bangladesh (AIUB), Dhaka, Bangladesh. The authors performed their investigative tasks at AIUB from September 2023 to February 2024.

Methodology: The air pollution analyzer was implemented using an Arduino Uno and dust sensor to generate and determine accurate air quality based on specific air contents. The system that was developed used a PM10 detection system that identified the amount of dust particles in the area. Based on PM10 readings, the air quality was identified. Moreover, the Air Quality Index (AQI) was determined using the PM10 readings. The LCD, buzzer, and multiple LEDs were used to display and indicate the air quality condition and levels.

Results: The portable air pollution analyzer was successfully tested and found to be accurate and reliable in determining air quality. To indicate different hazardous states of air, red, green, and yellow color LEDs are used. The test outcomes were very satisfactory.

Conclusion: This system demonstrates the use of a microcontroller in building a simple yet effective portable air quality detector. It can be scaled up for commercial production.

Keywords: Pollution analyzer; air quality; PM10; AQI; air quality index; portable; Arduino; microcontroller.

1. INTRODUCTION

Tiny particles in the air, known as dust, can cause problems for both people and nature. Dust in the air can deteriorate the air quality and affect air conditions that may cause human health hazards due to the rise of the concentration level of particulate matter (PM) [1], which may spread at tremendous heights during thrilling dust events [2-3]. To help with this, the research work made a system called a 'portable air quality detector'. This device uses a microcontroller, namely Arduino Uno, and a dust sensor, specifically DSM501A, to make a small and easy-to-use device. This device can tell how much dust is in the air around us and provides necessary information regarding the quality of air around us.

Dust comes from different places like factories, construction sites, cars, and even natural things. Breathing in too much dust for a long time can cause trouble with breathing and many diseases. The reason for making this device is to allow people to check how much dust is in the air around them. In this way, people can make choices to stay safe and healthy. A high concentration of dust particles in the air is never ideal. This causes various health issues. To warn people about it, a system like an air pollution analyzer can help the general people to know about the status of air in a certain area. There are various measuring systems to detect the quality of air. To detect the number of dust particles, PM10 is a common and widely used method [4]. Although PM10 is commonly used for scientific purposes, it is not widely popular with

the general people who are the main target users of our system. Hence a widely known and simple measuring system is required. Air Quality Index (AQI) is a type of measuring air quality that is commonly known to people via various weather applications. Using the values that are obtained through PM10, people can receive understandable AQI values and quality of air within seconds through a proper system.

In summary, this study focuses on designing a system that can detect the air quality of a certain area using a dust sensor capable of detecting dust particles in the PM10 range. The results obtained in PM10 will be converted to AQI values and the users on the system will be notified regarding the results. The key objective of this work is to design, simulate, and implement a portable air quality detector using an Arduino Uno microcontroller and PM10 dust sensor. The following are the specific system objectives:

- Design a circuit that can analyze the air around the system and determine the quality of the air.
- Develop a system to properly identify the air quality using PM10 detection regulations and methods.
- Present the results obtained by the system in a user-friendly representation using the Air Quality Index.
- Implement a 16x2 display to display the PM10 and AQI readings to users.
- Implement a method to wirelessly connect with the system and receive or read results obtained by the system.

- Test and validate the portable air quality detector to ensure it is accurate and reliable for detecting the air quality.

By achieving these objectives, the paper aims to develop a simple yet user-friendly portable air quality detector. The paper also seeks to provide a practical application of microcontrollers like Arduino Uno and equip the knowledge and skills required to design basic electronic systems. The system's goal is to provide people with a useful and affordable tool that helps them play an active role in tracking air quality. By successfully meeting these targets, the device contributes to increasing awareness about the environment, making well-informed choices, and taking proactive steps to reduce pollution.

2. LITERATURE REVIEW

Air is a vital element of human life. This important element is constantly being polluted in various ways. From the equipment we use to the industries that we are developing to make our life comfortable; all of these are polluting the air. Air pollution can have severe consequences for human health. People of susceptible health groups, such as children, aged people, and some other individuals with severe illness or chronic diseases are the prime victims of air pollution. That is why stopping air pollution has become an important matter these days. But stopping it all at once is a difficult task to accomplish. Various factors need to be considered, such as economic, political, law enforcement, and monitoring with many more issues. In this situation, electronics can help us [5]. The current world is called a smart world. The whole world is connected through various IoT devices. These devices sense our environment and connect with their surroundings in various ways. Various monitoring devices can be used to identify these conditions. This is where IoT devices come in. The key characteristics of IoT devices are connectivity, sensors, data processing and analytics, automation, control, and many more. IoT devices can determine the condition of our surroundings by various sensors and detection techniques and help us understand the current condition of our environment in a better and broader manner [6-9].

The most effective method to identify the poor conditions of the environment is using a compact device along with some sensors. These devices can be made with affordable and widely available components. These devices usually come with

various sensors like particle sensors, dust analyzers, and many more. All of these can determine various poisonous elements in the air. For a specific kind of particle, a specific sensor is used. Generally, laser light is used to determine the dust particles in the air. These devices scatter light on the particle and then determine the particle size range using the sensors that are integrated into the devices [10]. The Arduino Uno microcontroller board is built with an ATmega328P microcontroller. This is a very powerful component that can be used to design and develop a powerful IoT-based device, like an air quality detector [11] with a very low cost [12,13].

All the data that is collected using these devices needs to be shown to the user. The interface needs to be user-friendly and easy to access. Cloud connectivity is an important factor in this 21st century. Any device without cloud access is deemed to be smart. Therefore, the devices that are used for detecting the quality of air must have cloud access. This provides the user with unrestricted access to the data that is collected and can be easily used for various vital research or actions [14]. Any web-based application can be used over any device without making a particular part of the application. A web-based application for a device like an air condition monitoring device is crucial and demands time. Through this web application, users can view various data obtained through the microcontroller-based application over time. These data can be visually represented in various ways so that the user feels comfortable seeing the data that is obtained in this device. Moreover, users can view the air condition of the area at a moment's notice from any device that prefers using any wired or wireless medium that is available to the user [7-9,15].

3. METHODOLOGY

3.1 Working Principle and Flowchart of the Proposed System

In developing a portable air quality detector using Arduino Uno, a dust sensor will be utilized. In specific a dust sensor called DSM501A will be used [16]. The reason behind using this dust sensor is that it is affordable, widely available, and more accurate when detecting PM10 particles. Using this sensor, the rest of the circuit is designed based on the requirements that we have set. In Fig. 1, the proposed block diagram for the scheme is developed.

The general flow chart of the work for the proposed system starting from the initialization of the program to taking the readings and completing the reading and showing it on the 16x2 LCD and wireless devices is shown in Fig. 2.

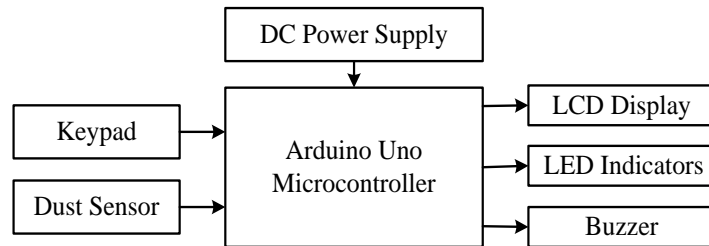

Fig. 1. Block diagram of the proposed scheme

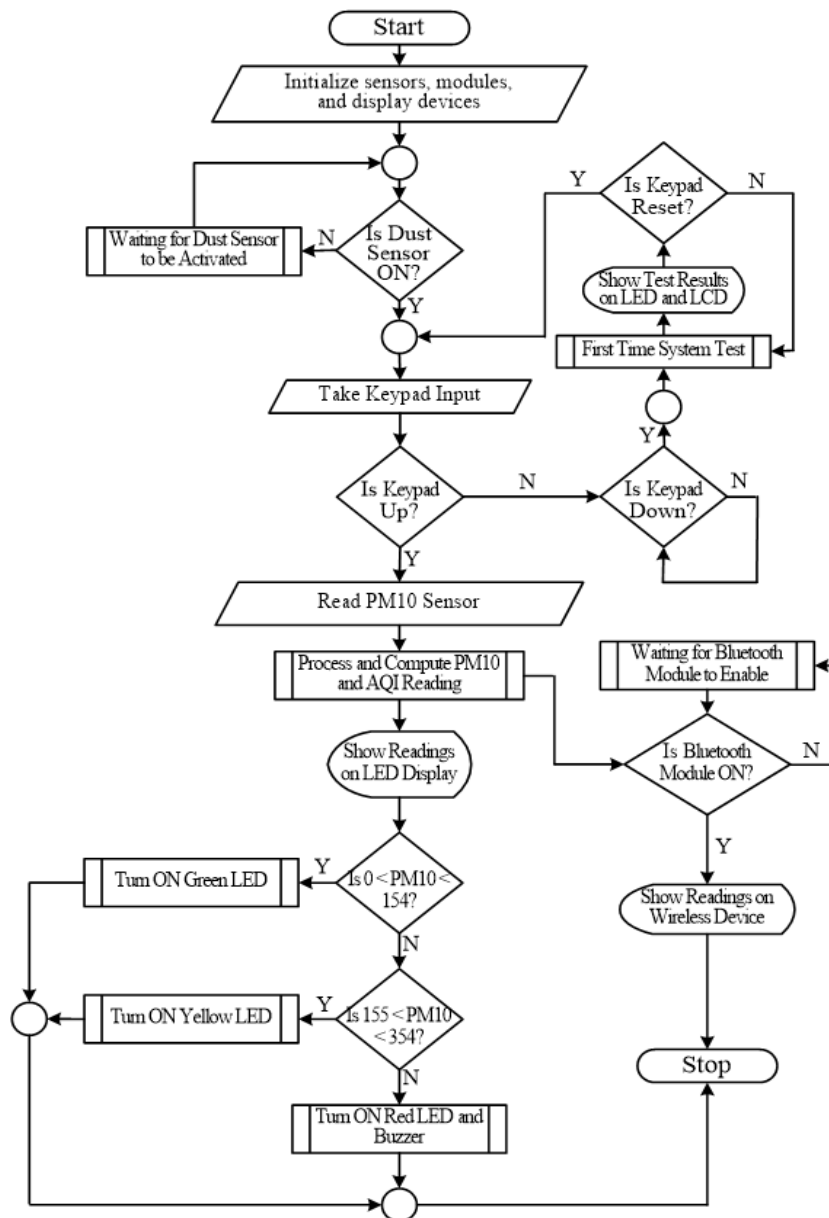

Fig. 2. Flowchart of the proposed system

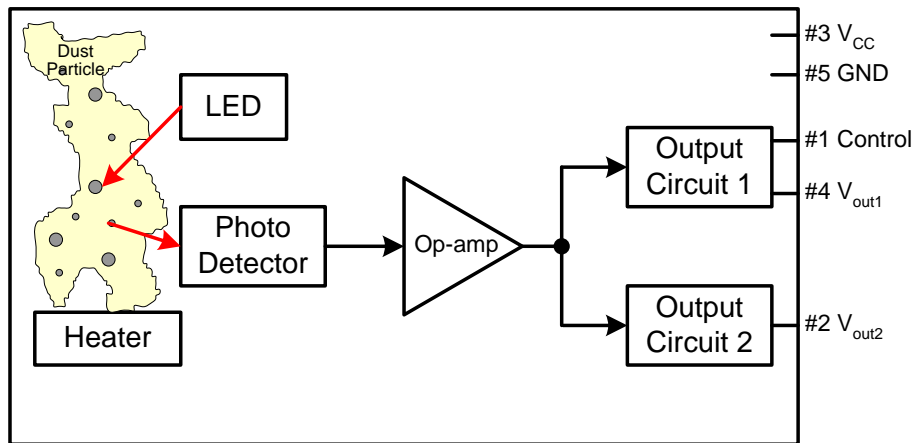

Fig. 3. Block diagram of the DSM501A sensor [17]

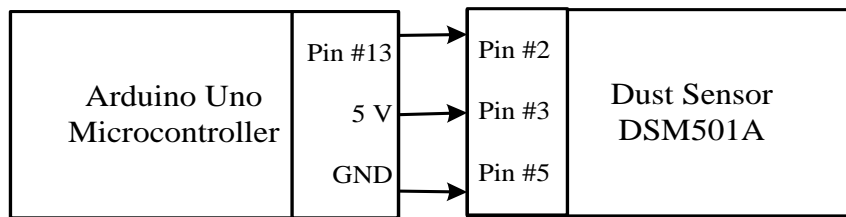

Fig. 4. Connection diagram of the DSM501A with Arduino Uno [18]

3.2 Process of the Work

The dust sensor, DSM501A detects the number of particles using an infrared LED, a detector in the sensor module, and an op-amp for signal amplification. It also comes with a heater to enhance the operating parameters. An amplification circuit is then used to amplify the detected signals and provide the output using two output circuits known as 'output circuit 1' and 'output circuit 2' as in Fig. 3 [17].

The data obtained from the DSM501A sensor will be delivered to a microcontroller for further operation. In this system, an Arduino Uno Microcontroller is used. The data that is obtained from the sensor will be sent to the Arduino Uno using pin 13. For this system specifically, pin 13 is vital as this is the pin that sends the relevant data regarding PM10 readings. A connection diagram of the DSM501A sensor and Arduino Uno microcontroller is shown in Fig. 4.

The obtained data is then processed in the code that is developed and set in the Arduino Uno microcontroller. There are three possible air quality conditions set in our system. They are 'Good', 'Unhealthy', and 'Hazardous'. For certain PM10 concentrations, each of these air qualities will be represented to the user. The user will be notified about the air quality using the LEDs. There are three LEDs in the system. Alongside PM10 values, AQI will also be determined using the values of PM10 chart and AQI equality. The AQI calculation equation is provided in equation (1).

$$AQI = \frac{AQI_{Hi} - AQI_{Lo}}{Conc_{Hi} - Conc_{Lo}} \times [(Conc_i - Conc_{Lo}) + AQI_{Lo}] \quad (1)$$

Here the $Conc_i$ is the value that is obtained from the DSM501A sensor through pin 13 of the Arduino Uno. The rest of the values are collected from Table 1 according to the condition of the air quality.

Table 1. AQI and concentration breakpoints of PM10

PM10 Air Quality	$Conc_{Lo}$	$Conc_{Hi}$	AQI_{Lo}	AQI_{Hi}
Good	0	154	0	100
Unhealthy	155	354	101	200
Hazardous	355	604	201	500

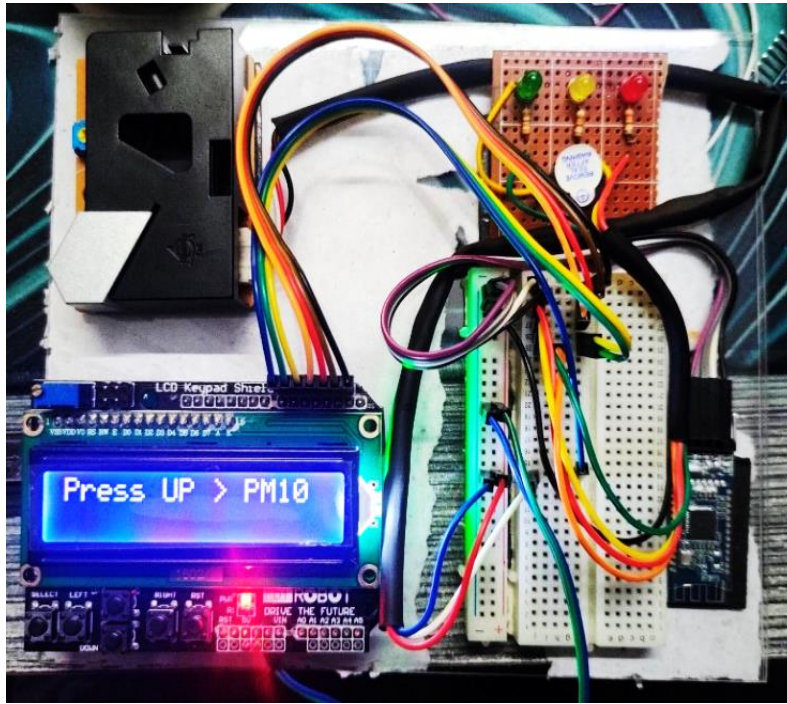

Fig. 5. Portable air quality detector using Arduino without acrylic cover.



Fig. 6. Portable air quality detector using Arduino with acrylic cover.

Based on the values of the table and the concentration value obtained from the dust sensor, the AQI value will be calculated and shown on the LED display. The AQI value is popularly known the people compared to PM10 values as AQI is commonly shown on various mobile weather applications. Hence, this is the biggest improvement over all other air quality sensors that are already in the market and developed by other previous engineers.

The results that are shown on the display of the LED are shown on the serial monitor. It is shown while connected with a USB cable with the Arduino Uno board at the Baud Rate that is set on the system. The results shown on the serial monitor are also shown on a remote device that is wirelessly connected by a wireless module. The wireless modules were set using the TX and RX pin of the Arduino Uno along with V_{cc} and Ground. Figs. 5 and 6 show the final system that is developed and implemented as a prototype. Fig. 5 shows the inside of the hardware of the prototype implementation of the portable air quality detection system without using the acrylic cover box. When the power is ON the system shows on the LCD screen what to do. If we press the upward button, then the system will start monitoring the air quality. There are three LEDs of three different colors. They indicate the various air quality states.

Fig. 6 shows the inside of the hardware of the prototype implementation of the portable air quality detection system with the acrylic cover box. Here, no power supply is applied.

4. RESULTS AND DISCUSSION

To perform an appropriate comparison between the simulated and experimental results, the AQI values at certain PM10 values were collected accordingly. Based on the obtained values the following Error Rate (%) formula (2) is used.

$$\text{Percentage of Error} = \frac{\text{Experimental Value} - \text{Simulated Value}}{\text{Experimental Value}} \times 100\% \quad (2)$$

The simulated results were collected using a simulation software called Proteus simulation tool [18]. The system was developed in the software and the simulated values were obtained from the simulation results. The experimental results were obtained by field testing it in different areas. Figs. 7-10 represent the system in a field test. Fig. 7 shows that the yellow LED is turned ON. The

corresponding values of PM10 and AQI are shown on the LCD screen of Fig. 7 as 246.71 and 146.62, respectively. That is, this indicates that the air quality is moderate for human health.

On the other hand, in Fig. 8, the LCD screen shows that the values of PM10 and AQI are 274.41 and 160.40, respectively. That is, this indicates that the air quality is unhealthy for human beings. As such, a red LED indicator is turned ON.

Similar types of results are displayed in Fig. 9, where a serial monitor of Arduino IDE shows these results. In this case, the system should be connected to a laptop via its serial port, in this figure it is the COM3 port of the laptop. This serial monitor displays two types of data based on the detected values of PM0 and AQI, such as hazardous and unhealthy.

Experimental AQI data from the prototype system is displayed in real-time on the Bluetooth-connected device including date and time in Fig. 10. This device displays three different sets of the detected values of PM0 and AQI, all of which are unhealthy.

The results obtained from the simulation and field test are shown in Table 2.

From Table 2, it can be observed that all the error ranges at different PM10 values are 0.20-1.12%, which is within an acceptable range. But if the system is used for scientific purposes this range of errors is not acceptable. The error is occurring because of several reasons which are human error and simulation error. In terms of human error, the DSM501A dust sensor is not providing appropriate results as several environmental issues can cause these errors. Various obstacles in the sensor can also cause such errors as well. In terms of simulation error, the appropriate dust sensor is not available in proteus simulation software and that is why an alternative sensor which is the MQ135 sensor is used. Although the used sensor in the simulation can detect dust particles at the PM10 range, it cannot provide results with such accuracy as that the DSM501A dust sensor can provide. The MQ135 sensor detects dust particles in a different method as well which is not like DSM501A dust sensor. For this reason, the simulation results are generating some errors.

To identify the affordability of the developed system over all the commercially available

products, a cost analysis was performed. Products that were purchased to develop the system were sourced from various sources to ensure the best possible price. As a small number of the components were purchased, the

prices are not as competitive as they would have been if the components were purchased in bulk. The prices of each product and purchase quality along with the total cost of developing the product are provided in Table 3.



Fig. 7. Experimental AQI data is displayed in real-time on the LCD screen.



Fig. 8. Experimental AQI data is displayed in real-time on the LCD screen with a red LED indicator.

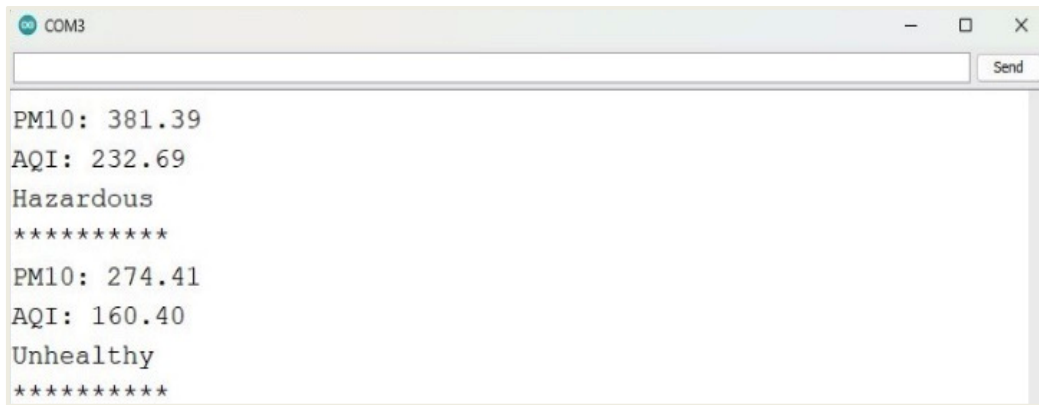

Fig. 9. Experimental AQI data is displayed in real-time on the serial monitor of the Arduino IDE.



Fig. 10. Experimental AQI data is displayed in real-time on the Bluetooth-connected device including date and time.

Table 2. Experimental and simulated AQI values at different PM10 values

PM10 Value	Experimental AQI Value	Simulated AQI Value	Error (%)
60.69	39.41	38.97	1.12
274.41	160.40	160.20	0.12
381.39	232.69	232.22	0.20

Table 3. Prices of the purchased required components of the proposed system

Sl. No.	Items	Quantity	Price (BDT)	Price (US\$)*
1	Arduino Uno Board	1	1100	10.00
2	HM10 Wireless Module	1	470	4.27
3	DSM501A Dust Sensor	1	890	8.09
4	Veroboard Dot Type	1	25	0.23
5	LCD Keypad Shield for Arduino	1	550	5.00
6	Buzzer	1	20	0.18
7	LEDs	3	15	0.14
8	Jumper wire	25~30	75	0.68
9	Resistor	3	10	0.09
10	Ribbon Tape	1	50	0.45
11	Acrylic Sheet	1	400	3.64
Total Prices in BDT and US\$, respectively			3605	32.77

Table 4. Prices of commercial air quality detectors

Sl. No.	Model Name	Price (BDT)	Price (US\$)*
1	Amazon Smart Air Quality Monitor	23499	214
2	Temtop Air Quality Monitor	13419	122
3	AcuRite Air Quality Monitor	13749	125
Average Price in BDT and US\$, respectively		16889	154

* Costs are given based on prices of the components in Bangladesh in Bangladeshi Taka (BDTK).
 But it may vary depending on the country of purchase and dollar rate.
 In general, 1 US\$ = 110 BDT [19]

As there are other commercial solutions available on the market already, a proper cost analysis of the developed product is vital. By searching the internet and physical shops during our research, the prices of a few noteworthy components were collected. The prices that were collected are represented in Table 4 for better understanding along with the average price of a commercial air quality detector.

In line with the commercial air quality detector device market evaluation, the market is going up cumulatively at a compound annual growth rate of 11.8%. The current market value of this product was estimated at US\$6.6 billion in 2023. It is predicted that this may continue to grow and may reach the value of US\$13.3 billion in 2033 subject to the persistence of this growth rate in the next 10 years from now. It is found that 45% of the total environmental parameters monitoring market is the air quality detection device market [20]. As such, the researchers must accomplish research significantly in this sector.

To identify the cost reduction of the system, the percentage of cost reduction formula is given by equation (3).

$$\text{Percentage of Cost Reduction} = \frac{\text{Original Value} - \text{New Value}}{\text{Original Value}} \times 100\% \quad (3)$$

Here, Original Value = the average price of the available systems; New Value = The proposed system price. Therefore, the percentage reduction of the cost can be found by using equation (3) as follows:

$$\text{Percentage of Cost Reduction} = \frac{16889 - 3605}{16889} \times 100\% = 78.65\%$$

According to the formula, the price can be reduced by 78.65%. However, this is without factoring in shipping, licensing, and delivery costs that will gradually add up to the new cost. Despite those additional expenditures, due to the

initial high-cost reduction, the price will stay at a value that will be deliverable to the masses. Besides, if orders for manufacturing PCBs are taken in bulk, this will result in further price reduction.

The developed system in the report has some limitations. The limitations happened due to various reasons. Here are the noteworthy limitations of the system:

- The developed system cannot detect smaller particles like PM2.5 accurately as the DSM501A dust sensor cannot detect this kind of matter appropriately. The reason behind this is the sensor that the DSM501A uses.
- The developed portable air quality detector cannot run appropriately in an industrial area as it cannot detect PM2.5 particles.
- The system does not have a fully developed computer application that can help read the results in a user-friendly interface.
- The system does not come with a mobile application that can connect with the system automatically and view the results using a standalone application.
- A notification alert system is not developed for the system that can alert the user wirelessly through their mobile or computer.
- The system is not waterproof and as a result, it cannot be permanently set in the open environment.
- The DSM501A dust sensor that is used can provide inaccurate readings of PM10 particles if the sensor is blocked by any medium.

5. CONCLUSION

In conclusion, the portable air quality detector using Arduino Uno demonstrates the possibility of developing air quality detectors in a simple, affordable, and user-friendly manner. This

system has developed an air quality detector that can detect PM10 particles with high accuracy. Based on the information it gathers, it can also present the AQI value based on the PM10 concentration detected by the system. This device has also demonstrated that an air quality detector can be developed by any simple person using a microcontroller like Arduino Nano, Uno, and many more. Through analysis and testing, it has been determined that all the knowledge obtained from the project was implemented accordingly and it can detect the quality of the air in a particular area with high accuracy. Thus, the main purpose of this device has been fulfilled and the system has achieved its objectives of designing and constructing a functional portable air quality detector using Arduino Uno. In terms of future endeavors, several potential improvements can be made to enhance the portable air quality detector's functionality and accuracy. Here are some of the proposed future endeavors:

- The system can be used in industrial areas if the sensor is changed to be a better and high-accuracy detection one. As PM2.5 is the ideal measuring range for industrial air quality detection, purchasing a dust sensor that can detect such particles can enhance the operation of the product that has been developed.
- As DSM501A Dust Sensor is a sensitive component that is highly prone to get damaged due to its cheap build quality, searching for a durable sensor can be a part of the future endeavor while keeping the thought of making it affordable for the general people.
- DSM501A dust sensor can easily obstruct big dust particles. Hence, the sensor requires constant cleaning. Developing a system so that it does not require constant cleaning regularly is research that will take time and effort.
- The device can be made cost-effective with automated manufacturing processes to speed up production and reduce labor costs, while also ensuring consistency and quality control. The purchase of bulk products can also reduce costs. Finding a possible solution for that can be an important section of future endeavors.
- Developing an application on which the user can view the condition of the air around them is vital. As this will take time and enhance programming knowledge, this can be a part of future endeavors as well.

COMPETING INTERESTS

The authors have declared that no competing interests exist.

REFERENCES

1. Zhang X, Zhao L, Tong DQ, Wu G, Dan M, Teng B, A systematic review of global desert dust and associated human health effects, *Journal of Atmosphere*, MDPI. December 2016; 7:158(12):1-30. Available: <https://doi.org/10.3390/atmos7120158>
2. Kim H-S, Chung Y-S, Satellite and ground observations for large air pollution transport in Yellow Sea region, *Journal of Atmospheric Chemistry*. September 2008; 60:103-116. Available: <https://doi.org/10.1007/s10874-008-9111-4>
3. Kim H-S, Chung Y-S, Lee S-G, Characteristics of aerosol types during large-scale transport of air pollution over the Yellow Sea region and at Cheongwon, Korea, in 2008, *Journal of Environmental Monitoring and Assessment*. April 2012; 184:1973-1984. Available: <https://doi.org/10.1007/s10661-011-2092-9>
4. Suryati I, Khair H, Gusrianti D, Analysis of air quality index distribution of PM10 and O3 concentrations in ambient air of Medan city, Indonesia, *Journal of Physical Science*. 2018; 29 (Supp.3):37-48. Available: <https://doi.org/10.21315/jps2018.29.s3.5>.
5. Sachdeva M. Air pollution and its treatment using technology, *Journal of Mechanical and Civil Engineering, India*, ISSN: 2456-1479. February 2015;1(2):06-14. DOI: 10.52589/ijmce.
6. Choudhari I, Air quality/air pollution monitoring system, using IoT, *International Research Journal of Modernization in Engineering Technology and Science, India*, ISSB: 2582-5208. September 2022;4(9):1337-1341. Available: <https://www.doi.org/10.56726/IRJMETS30065>
7. Biswas S, Bhuyan MH, Hasan MK. IoT-based automated solar panel cleaning and monitoring technique, *Journal of Engineering Research and Reports*, ISSN: 2582-2926. 2 September 2023;25 (8):JERR.105650,56-69.

8. Paul NK, Saha D, Biswas K, Akter S, Islam RT, Bhuyan MH, Smart trash collection system – an IoT and microcontroller-based scheme, Journal of Engineering Research and Reports, ISSN: 2582-2926. 3 April 2023;24(11): Article no. JERR.98321,1-13.
9. Bhuyan MH, Ali MA, Khan SA, Islam MR, Islam T, Akter J, Design and implementation of solar power and an IoT-based pisciculture management system, Journal of Engineering Research and Reports, ISSN: 2582-2926. January 2023;24(2): Article no. JERR.95811,15-27.
10. Dige AS, Tandle SR. Air pollution monitoring system based on ESP8266 using Arduino, International Journal of Engineering Applied Sciences and Technology, India, ISSN: 2455-2143. October 2020;5(6):228-235. Available: <https://doi.org/10.33564/ijeast.2020.v05i06.034>
11. Afroze S, Paran MIH, Roki RH, IoT-based air quality monitoring system using Arduino, International Journal for Multidisciplinary Research (IJFMR), India, 2582-2160. March 2023;5(2):1-12. Available: <https://doi.org/10.36948/ijfmr.2023.v05i02.2260>
12. Bhuyan MH, Sheikh M, Designing, implementing, and testing of a microcontroller and IoT-based pulse oximeter device, IOSR Journal of Electrical and Electronics Engineering (IOSR-JEEE), IF=3.26, ISSN: e-2278-1676, p-2320-3331. September-October 2021;16(5)series-2:38-48.
13. Bhuyan MH, Hasan MT, Iskander H, Low-cost microcontroller based ECG machine, International Journal of Biomedical and Biological Engineering. 2020;14(7): 192-199. e-ISSN: 1307-6892
14. Rathi BS, Sakhare AN, Indore SB, Suryawanshi SD, Jadhav SS. Air quality monitoring using Arduino and cloud-based system in IoT, International Journal for Research in Applied Science & Engineering Technology, India, 2321-9653. July 2022;10(7):4655-4659. Available: <https://doi.org/10.22214/ijraset.2022.45846>
15. Khodve SR, Kulkarni AN, Web-based air pollution monitoring system (air pollution monitoring using a smartphone), International Journal of Science and Research (IJSR), India, 319-7064. March 2016;5(3):266-269. Available: <https://doi.org/10.21275/v5i3.nov161795>.
16. Soica FF, Egri A, Stanimirescu A, Analysis of quality indicators from slurry decanters, Editura Universitatii Petrosani, Romania, ISSN: 1454-9166. 2018;105.
17. Dust Sensor, DSM501A Data Sheet, and Block Diagram;2023. Available: <https://www.electronicclinic.com/dust-sensor-dsm501a-with-arduino-pm10-pm2-5-air-quality-monitoring/>, accessed on 25 August 2023
18. Bhuyan MH, Hasan M, Design and simulation of a heartbeat measurement system using Arduino microcontroller in proteus, International Journal of Biomedical and Biological Engineering. 2020;14(10): 350-357. e-ISSN: 1307-6892
19. Currency Conversion Rate from US Dollar to Bangladeshi Taka and vice-versa;2024. Available: <https://www.xe.com/currencyconverter/convert/?Amount=1&From=USD&To=BDT>, web page access date 18 March 2024.
20. The global air quality monitoring equipment market size projection and growth rate;2024. Available: <https://www.futuremarketinsights.com/reports/air-quality-monitoring-equipment-market>, web page access date 18 March 2024.

© Copyright (2024): Author(s). The licensee is the journal publisher. This is an Open Access article distributed under the terms of the Creative Commons Attribution License (<http://creativecommons.org/licenses/by/4.0>), which permits unrestricted use, distribution, and reproduction in any medium, provided the original work is properly cited.

Peer-review history:
The peer review history for this paper can be accessed here:
<https://www.sdiarticle5.com/review-history/115862>